

FMS Medium-Duty Secondary

Installation, Operation and Maintenance Manual



MHS HD Secondary Cleaner

Serial Number: _____
Purchase Date: _____
Purchased From: _____
Installation Date: _____

Serial number information can be found on the Serial Number Label included in the Information Packet found in the cleaner carton.

This information will be helpful for any future inquiries or questions about belt cleaner replacement parts, specifications or troubleshooting.

Table of Contents

Section 1 - Important Information	4
1.1 General Introduction.....	4
1.2 User Benefits	4
1.3 Service Option.....	4
Section 2 - Safety Considerations and Precautions	5
2.1 Stationary Conveyors.....	5
2.2 Operating Conveyors.....	5
Section 3 - Pre-Installation Checks and Options.....	6
3.1 Checklist.....	6
3.2 Optional Installation Accessories.....	7
Section 4 - Installation Instructions.....	8
4.1 Installation Instructions - FMS with MST Tensioner.....	8
Section 5 - Pre-Operation Checklist and Testing.....	11
5.1 Pre-Op Checklist.....	11
5.2 Test Run the Conveyor	11
Section 6 - Maintenance.....	12
6.1 New Installation Inspection.....	12
6.2 Routine Visual Inspection.....	12
6.3 Routine Physical Inspection	12
6.4 Maintenance Log.....	13
6.5 Cleaner Maintenance Checklist.....	14
Section 7 - Troubleshooting	15
Section 8 - Specs and CAD Drawings.....	16
8.1 Specs and Guidelines	16
8.2 CAD Drawing - FMS Cleaners with MST Tensioners	17
Section 9 - Replacement Parts	18
9.1 Replacement Parts.....	18
Section 10 - Other Flexco Conveyor Products	19

Section 1 - Important Information

1.1 General Introduction

We at Flexco are very pleased that you have selected an FMS Medium-Duty Secondary Cleaner for your conveyor system.

This manual will help you to understand the operation of this product and assist you in making it work up to its maximum efficiency over its lifetime of service.

It is essential for safe and efficient operation that the information and guidelines presented be properly understood and implemented. This manual will provide safety precautions, installation instructions, maintenance procedures and troubleshooting tips.

If, however, you have any questions or problems that are not covered, please contact your field representative or our Customer Service Department:

Customer Service: USA: 1-800-541-8028

Visit www.flexco.com for other Flexco locations and products.

Please read this manual thoroughly and pass it on to any others who will be directly responsible for installation, operation and maintenance of this cleaner. While we have tried to make the installation and service tasks as easy and simple as possible, **it does however require correct installation and regular inspections and adjustments to maintain top working condition.**

1.2 User Benefits

Correct installation and regular maintenance will provide the following benefits for your operation:

- Reduced conveyor downtime
- Reduced man-hour labor
- Lower maintenance budget costs
- Increased service life for the belt cleaner and other conveyor components

1.3 Service Option

The FMS Medium-Duty Secondary Cleaner is designed to be easily installed and serviced by your on-site personnel. However, if you would prefer complete turn-key factory service, please contact your local Flexco Field Representative.

Section 2 - Safety Considerations and Precautions

Before installing and operating the FMS Medium-Duty Secondary Cleaner, it is important to review and understand the following safety information.

There are set-up, maintenance and operational activities involving both **stationary** and **operating** conveyors. Each case has a safety protocol.

2.1 Stationary Conveyors

The following activities are performed on stationary conveyors:

- Installation
- Blade replacement
- Repairs
- Tension adjustments
- Cleaning

DANGER

It is imperative that OSHA/MSHA Lockout/Tagout (LOTO) regulations, 29 CFR 1910.147, be followed before undertaking the preceding activities. Failure to use LOTO exposes workers to uncontrolled behavior of the belt cleaner caused by movement of the conveyor belt. Severe injury or death can result.

Before working:

- Lockout/Tagout the conveyor power source
- Disengage any takeups
- Clear the conveyor belt or clamp securely in place

WARNING

Use Personal Protective Equipment (PPE):

- Safety eyewear
- Hardhats
- Safety footwear

Close quarters, springs and heavy components create a worksite that compromises a worker's eyes, feet and skull.

PPE must be worn to control the foreseeable hazards associated with conveyor belt cleaners. Serious injuries can be avoided.

2.2 Operating Conveyors

There are two routine tasks that must be performed while the conveyor is running:

- Inspection of the cleaning performance
- Dynamic troubleshooting

DANGER

Every belt cleaner is an in-running nip hazard. Never touch or prod an operating cleaner. Cleaner hazards cause instantaneous amputation and entrapment.

WARNING

Belt cleaners can become projectile hazards. Stay as far from the cleaner as practical and use safety eyewear and headgear. Missiles can inflict serious injury.

WARNING

Never adjust anything on an operating cleaner. Unforseeable belt projections and tears can catch on cleaners and cause violent movements of the cleaner structure. Flailing hardware can cause serious injury or death.

Section 3 - Pre-installation Checks and Options

3.1 Checklist

- Check that the cleaner size is correct for the beltline width
- Check the belt cleaner carton and make sure all the parts are included
- Review the “Tools Needed” list on the top of the installation instructions
- Check the conveyor site:
 - Will the cleaner be installed on a chute
 - Is the install on an open head pulley requiring mounting structure (see 3.2 - Optional Installation Accessories)

Section 3 - Pre-installation Checks and Options

3.2 Optional Installation Accessories

Optional Mounting Kits (includes 2 brackets/bars)			
Description	Ordering Number	Item Code	Wt. Lbs.
Pole Extender Kit	MAPEK	76024	21.9
MST Drop Bracket Kit	MSTDB	79434	27.7

Lead time: 1 working day

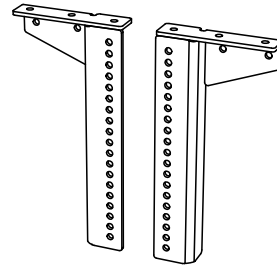

79434
MST Drop Bracket Kit (includes 2 brackets)

76024

Pole Extender Kit (includes 2 pole extenders)

- For cleaner sizes 72" (1800mm) and larger
- Provides 30" (750mm) of extended pole length

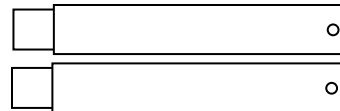

Section 4 - Installation Instructions

4.1 FMS Medium-Duty Secondary Cleaner for belts 18" - 72" (450-1800mm)

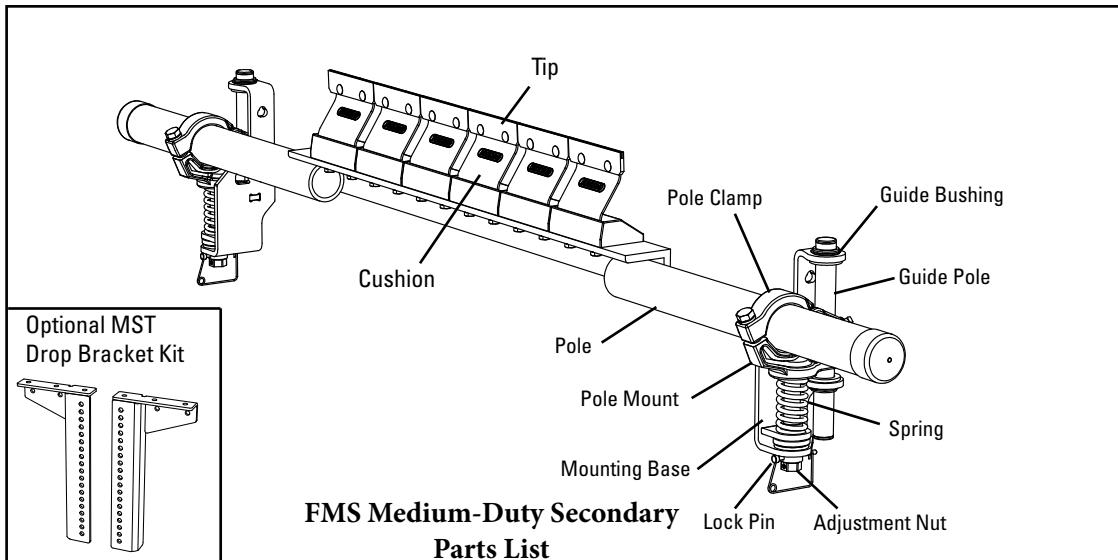

Physically lock out and tag the conveyor at the power source before you begin cleaner installation.

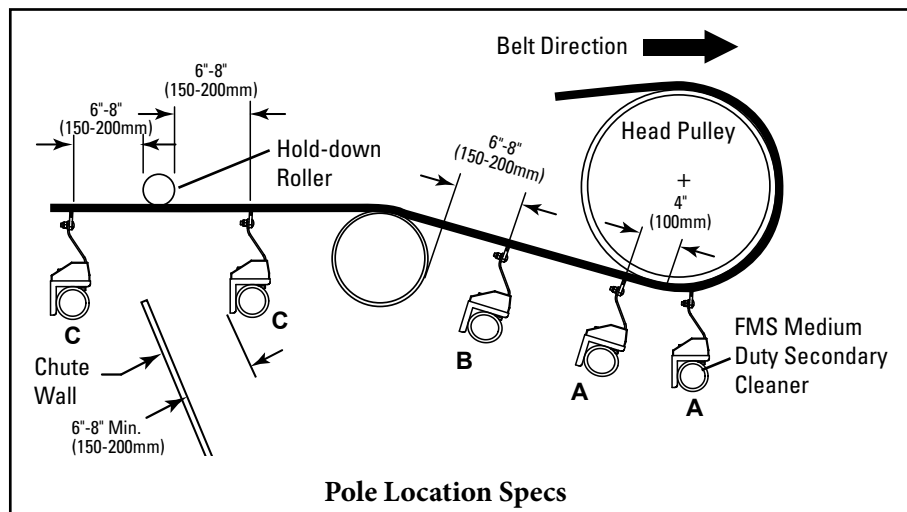

Tools Needed

- Adjustable Wrench
- OR
- 3/8" (10mm) Wrench
- 9/16" (14mm) Wrench
- 3/4" (19mm) Wrench
- 1" (25mm) Wrench
- 1 1/8" (29mm) Wrench
- Tape Measure
- Ratchet With 3/4" (19mm) Socket
- (2) 6" C-Clamps (for Temporary Positioning of Mounting Brackets)
- Cutting Torch and/or Welder
- Marking Pen

Section 4 - Installation Instructions

4.1 FMS Medium-Duty Secondary Cleaner

1. **Install the spring tensioner mounting bases.** The preferred mounting orientation relative to belt direction is shown in Fig. 1a; if necessary the tensioners may be mounted with the opposite belt direction. Clamp the mounting base into position so the top flange is 4" (102mm) below the bottom of the belt. Bolt or weld the mounting base in place. Locate and install the mounting base on the opposite side. Remove the tensioner lock pins and turn the adjustment nuts to fully lower the pole mount.

Note: For chute mounting, a belt location line must be drawn on the chute wall so the mounting base can be aligned 4" (102mm) below the belt (Fig. 1b). Cut access holes as needed.

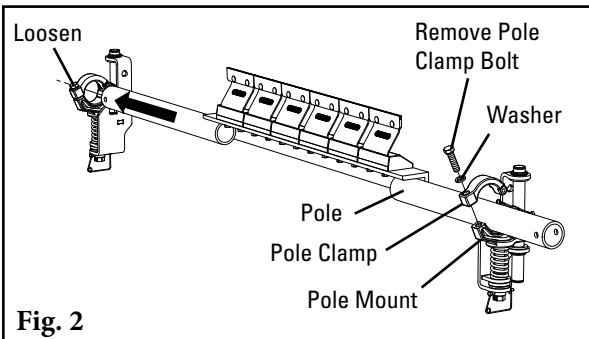
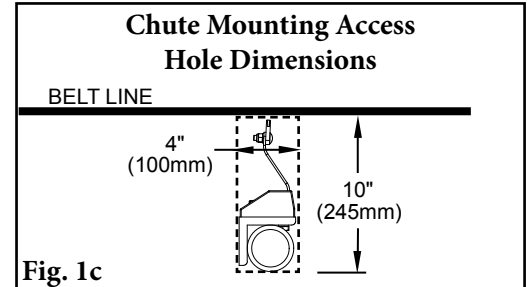
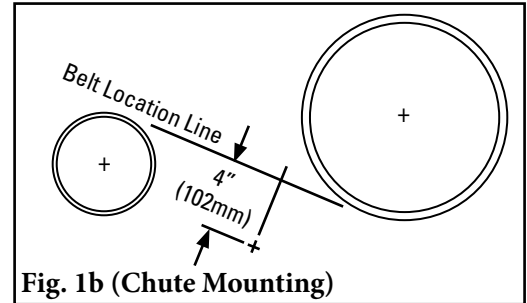
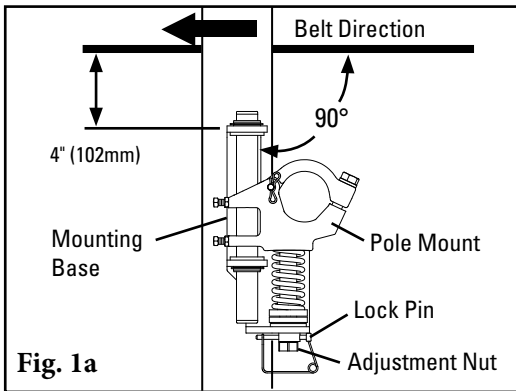

2. **Install the pole.**

Remove pole clamp bolt and lift or remove top half of pole clamp from the tensioner on the near side of the conveyor, and loosen pole clamp bolt on the opposite side. Slide the pole across the conveyor and through the loosened pole clamp, then place the near end of pole in remaining pole clamp (Fig. 2). Replace top half of pole clamp, reinstall the bolt and tighten both bolts finger tight.

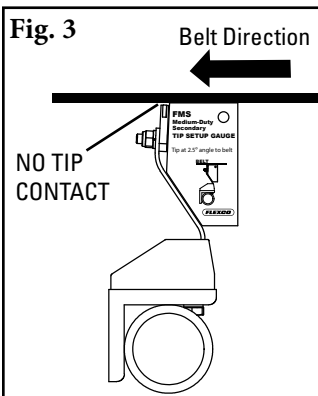

3. **Set the blade angle.** Center the pole/blades on the belt. Rotate the pole until the tips align with the FMS tip setup gauge provided (Fig. 3). Tighten the pole clamp bolt on each pole mount to lock the pole in place. There should be no blade-to-belt contact while locking the pole in the correct position. If contact occurs, double check the dimension from Step 1.

Section 4 - Installation Instructions

4.1 FMS Medium Duty Secondary Cleaner

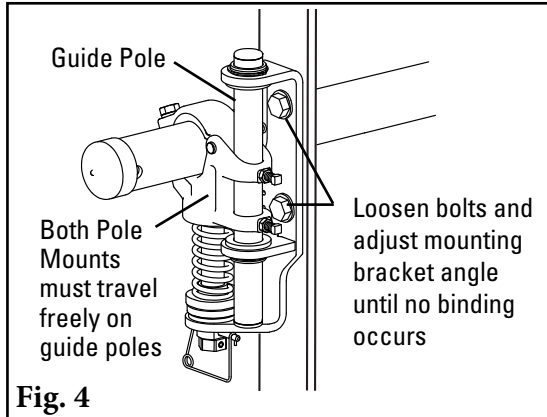

Fig. 4

4. **Ensure the tensioner travels freely.** Pull up and push down on each pole end to ensure the pole mount travels freely on the guide pole. If there is any sign of binding, loosen the bolts on the mounting base and pivot until the tensioner moves freely (Fig. 4). Retighten bolts.

5. **Set the blade tension.** Turn the adjustment nuts until the correct spring compression is reached (Fig. 5). Spring compression is determined by the spring length. See the chart below for the correct spring length for your belt width. Replace locking pins.

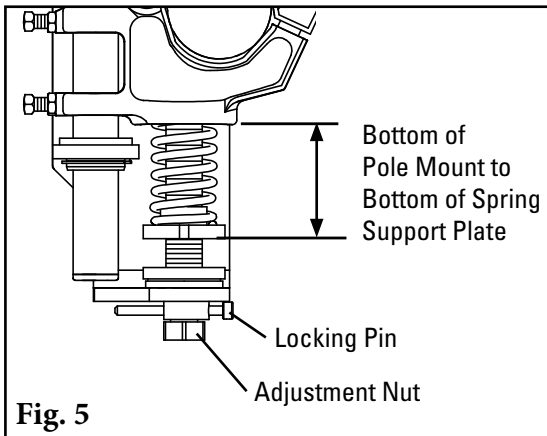

Fig. 5

MST Tensioner Spring Length Chart

Blade Width		2 White Springs		2 Silver Springs		2 Black Springs	
in.	mm	in.	mm	in.	mm	in.	mm
18	450	2 7/8	73	3 1/2	89	3 1/2	89
24	600	2 5/8	67	3 3/8	86	3 1/2	89
30	750	2 3/8	60	3 1/4	83	3 3/8	86
36	900	2 1/8	54	3 1/8	79	3 1/4	83
42	1050	N/A	N/A	3	76	3 1/8	79
48	1200	N/A	N/A	2 7/8	73	3 1/8	79
54	1350	N/A	N/A	2 3/4	70	3	76
60	1500	N/A	N/A	2 3/4	70	2 7/8	73
72	1800	N/A	N/A	N/A	N/A	2 3/4	70

Shading indicates preferred spring option.

6. **Secure guide poles.** Ensure the ends of the guide pole extend at least 1/2" (13mm) outside top and bottom guide bearings. If adjustment is necessary, loosen guide pole set screws and lock nuts, then tap guide pole up or down. Tighten guide pole set screws and lock nuts (Fig. 6).
7. **Check movement of each tensioner** to ensure they do not bind up. If there are binding concerns, refer to Step 4.
8. **Test run the cleaner and inspect the cleaning performance.** If vibration occurs or more cleaning efficiency is desired, increase the blade tension by making 1/8" (3mm) compression adjustments on the tension springs.

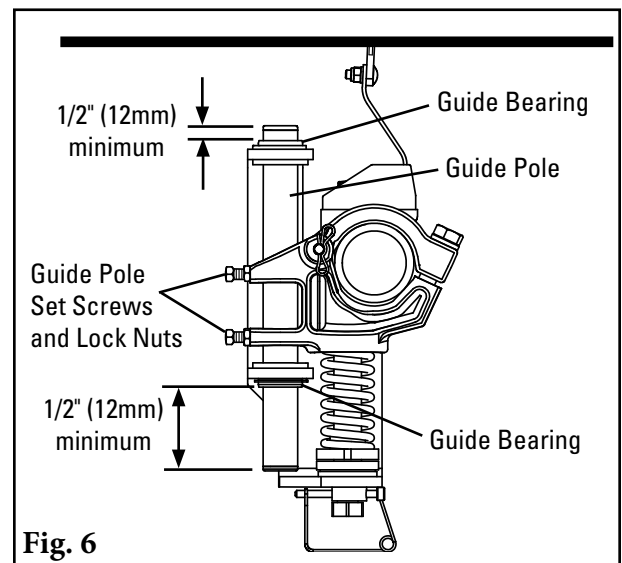

Fig. 6

Section 5 - Pre-Operation Checklist and Testing

5.1 Pre-Op Checklist

- Recheck that all fasteners are tightened properly
- Add pole caps
- Apply all supplied labels to the cleaner
- Check the blade location on the belt
- Be sure that all installation materials and tools have been removed from the belt and the conveyor area

5.2 Test Run the Conveyor

- Run the conveyor for at least 15 minutes and inspect the cleaning performance
- Check the tensioner spring for recommended length (proper tensioning)
- Make adjustments as necessary

NOTE: Observing the cleaner when it is running and performing properly will help to detect problems or when adjustments are needed later.

Section 6 - Maintenance

Flexco belt cleaners are designed to operate with minimum maintenance. However, to maintain superior performance some service is required. When the cleaner is installed a regular maintenance program should be set up. This program will ensure that the cleaner operates at optimal efficiency and problems can be identified and fixed before the cleaner stops working.

All safety procedures for inspection of equipment (stationary or operating) must be observed. The FMS Belt Cleaner operates at the discharge end of the conveyor and is in direct contact with the moving belt. Only visual observations can be made while the belt is running. Service tasks can be done only with the conveyor stopped and by observing the correct lockout/tagout procedures.

6.1 New Installation Inspection

After the new cleaner has run for a few days a visual inspection should be made to ensure the cleaner is performing properly. Make adjustments as needed.

6.2 Routine Visual Inspection (every 2-4 weeks)

A visual inspection of the cleaner and belt should look for:

- If spring length is the correct length for optimal tensioning
- If belt looks clean or if there are areas that are dirty
- If blade is worn out and needs to be replaced
- If there is damage to the blade or other cleaner components
- If fugitive material is built up on cleaner or in the transfer area
- If there is cover damage to the belt
- If there is vibration or bouncing of the cleaner on the belt
- If a snub pulley is used, a check should be made for material buildup on the pulley
- Significant signs of carryback

If any of the above conditions exist, a determination should be made on when the conveyor can be stopped for cleaner maintenance.

6.3 Routine Physical Inspection (every 6-8 weeks)

When the conveyor is not in operation and properly locked and tagged out, a physical inspection of the cleaner to perform the following tasks:

- Clean material buildup off of the cleaner blade and pole
- Closely inspect the blade for wear and any damage. Replace if needed.
- Ensure full blade to belt contact
- Inspect the cleaner pole for damage
- Inspect all fasteners for tightness and wear. Tighten or replace as needed.
- Replace any worn or damaged components
- Check the tension of the cleaner blade to the belt. Adjust the tension if necessary using the chart on the cleaner or the one on Page 10.
- When maintenance tasks are completed, test run the conveyor to ensure the cleaner is performing properly.

Section 6 - Maintenance

6.4 Maintenance Log

Conveyor Name/No. _____

Date: _____ Work done by: _____ Service Quote # _____

Activity: _____

Date: _____ Work done by: _____ Service Quote # _____

Activity: _____

Date: _____ Work done by: _____ Service Quote # _____

Activity: _____

Date: _____ Work done by: _____ Service Quote # _____

Activity: _____

Date: _____ Work done by: _____ Service Quote # _____

Activity: _____

Date: _____ Work done by: _____ Service Quote # _____

Activity: _____

Date: _____ Work done by: _____ Service Quote # _____

Activity: _____



Section 6 - Maintenance

6.5 Cleaner Maintenance Checklist

Belt Cleaner: _____ Serial Number: _____

Beltline Information:

Beltline Number: _____ Belt Condition: _____

Belt Width: 18" 24" 30" 36" 42" 48" 54" 60" 72"
(450mm) (600mm) (750mm) (900mm) (1050mm) (1200mm) (1350mm) (1500mm) (1800mm)

Belt Speed: _____ fpm Belt Thickness: _____

Belt Splice _____ Condition of Splice _____ Number of splices _____ Skived Unskived

Material conveyed _____

Days per week run _____ Hours per day run _____

Blade Life:

Date blades installed: _____ Date blades inspected: _____ Estimated blade life: _____

Are blades making complete contact with belt? Yes No

Blade wear: LEFT _____ MIDDLE _____ RIGHT _____

Blade condition: Good Grooved Smiled Not contacting belt Damaged

Measurement of spring: Required _____ Currently _____

For SAT2 Tensioner only: Air/Nitrogen Pressure Required _____ Currently _____
Inspect SAT2 bags and lines

Was Cleaner Adjusted: Yes No

Pole Condition: Good Bent Worn

Lagging: Slide lag Ceramic Rubber Other None

Condition of lagging: Good Bad Other _____

Cleaner's Overall Performance: (Rate the following 1 - 5, 1 = very poor - 5 = very good)

Appearance: Comments: _____

Location: Comments: _____

Maintenance: Comments: _____

Performance: Comments: _____

Other Comments: _____

Section 7 - Troubleshooting

Problem	Possible Cause	Possible Solutions
Vibration	Cleaner secure bolts not set	Ensure all locking nuts are tight (Loctite)
	Cleaner not set up correctly	Ensure cleaner set up properly (check tip angle with gauge) 1°-3° into belt
	Belt tension too high	Ensure cleaner can conform to belt, or replace with alternate Flexco secondary cleaner
	Belt flap	Introduce hold-down roller to flatten belt
	Cleaner over-tensioned	Ensure cleaner is correctly tensioned
	Cleaner under-tensioned	Ensure cleaner is correctly tensioned
	UHMW bearing worn out or missing	Replace bearing
Material buildup on cleaner	Cleaner not set up correctly	Ensure cleaner set up properly (1°-3° into belt)
	Buildup on chute	Ensure cleaner is not located too close to back of chute, allowing buildup
	Cleaner being overburdened	Introduce Flexco precleaner
	Excessive sticky material	Frequently clean unit of buildup
Damaged belt cover	Cleaner over-tensioned	Ensure cleaner is correctly tensioned
	Cleaner blade damage	Check blade for wear, damage and chips, replace where necessary
	Attack angle not correct	Ensure cleaner set up properly (check tip angle with gauge) 1°-3° into belt
	Material buildup in chute	Frequently clean unit of buildup
Cleaner not conforming to belt	Cleaner not set up correctly	Ensure cleaner set up properly (check tip angle with gauge) 1°-3° into belt
	Belt tension too high	Ensure cleaner can conform to belt (introduce hold-down roller), or replace with alternate Flexco secondary cleaner
	Belt flap	Introduce hold-down roller to flatten belt
	Cleaner cannot conform	Ensure cleaner can conform to belt (introduce hold-down roller), or replace with alternate Flexco secondary cleaner
Material passing cleaner	Cleaner not set up correctly	Ensure cleaner set up properly (check tip angle with gauge) 1°-3° into belt
	Cleaner tension too low	Ensure cleaner is correctly tensioned
	Cleaner blade worn/damaged	Check blade for wear, damage and chips, replace where necessary
	Cleaner being overburdened	Introduce Flexco precleaner
	Belt flap	Introduce hold-down roller to flatten belt
	Belt worn or grooved	Introduce water spray pole or brush cleaner
	Cleaner cannot conform	Ensure cleaner can conform to belt (introduce hold-down roller), or replace with alternate Flexco secondary cleaner
	Blade in backwards	Install blade correctly and set correct tension
Damage to mechanical fastener	Incorrect cleaner blade selection	Change blade type to accommodate fastener style (C or V)
	Belt not skived correctly	Spot and redo splice correctly, lowering the profile flush or below belt surface
	Blade angle incorrect	Reset with gauge
Missing material in belt center only	Cupped Belt	Install hold-down roller and reset blade angle with gauge
	Cleaner blade worn/damaged	Check blade for wear, damage and chips, replace where necessary
Missing material on outer edges only	Cupped Belt	Install hold-down roller and reset blade angle with gauge
	Cleaner blade worn/damaged	Check blade for wear, damage and chips, replace where necessary
MST Tensioners binding	Tensioners not aligned properly	Adjust mounting bases until tensioners travel without binding
	Material buildup on tensioner guide pole	Clean off guide pole

Section 8 - Specs and CAD Drawings

8.1 Specs and Guidelines

Pole Length Specifications*

CLEANER SIZE		BLADE WIDTH		POLE LENGTH		MAXIMUM CONVEYOR SPAN	
in.	mm	in.	mm	in.	mm	in.	mm
18	450	18	450	72	1800	62	1550
24	600	24	600	78	1950	68	1700
30	750	30	750	84	2100	74	1850
36	900	36	900	90	2250	80	2000
42	1050	42	1050	96	2400	86	2150
48	1200	48	1200	102	2550	92	2300
54	1350	54	1350	108	2700	98	2450
60	1500	60	1500	114	2850	104	2600
72	1800	72	1800	126	3150	116	2900
84	2100	84	2100	138	3450	128	3200
96	2400	96	2400	150	3750	140	3500

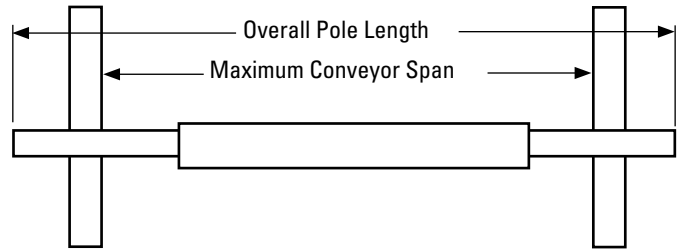

*For special extra long pole length requirements a Pole Extender Kit (#76024) is available that provides 30" (750mm) of extended pole length. See Page 7.
Pole Diameter - 2-7/8" (73mm)

Clearance Guidelines for Installation

HORIZONTAL CLEARANCE REQUIRED		VERTICAL CLEARANCE REQUIRED	
in.	mm	in.	mm
3-1/2	89	10	245

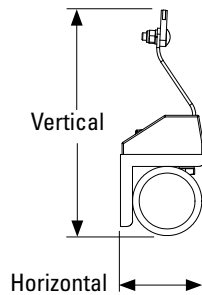

MST Tensioner Spring Length Chart

Blade Width		2 White Springs		2 Silver Springs		2 Black Springs	
in.	mm	in.	mm	in.	mm	in.	mm
18	450	2 7/8	73	3 1/2	89	3 1/2	89
24	600	2 5/8	67	3 3/8	86	3 1/2	89
30	750	2 3/8	60	3 1/4	83	3 3/8	86
36	900	2 1/8	54	3 1/8	79	3 1/4	83
42	1050	N/A	N/A	3	76	3 1/8	79
48	1200	N/A	N/A	2 7/8	73	3 1/8	79
54	1350	N/A	N/A	2 3/4	70	3	76
60	1500	N/A	N/A	2 3/4	70	2 7/8	73
72	1800	N/A	N/A	N/A	N/A	2 3/4	70

Shading indicates preferred spring option. Measure spring as shown.

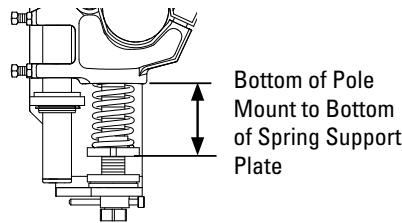

- Maximum Belt Speed 1000 FPM (5M/sec)
- Temperature Rating -30°F to 180°F (-35°C to 82°C)
- Usable Blade Wear Length 3/8" (9mm)
- Blade Materials C-Tip: Impact Resistant Tungsten Carbide (works with mechanical fasteners)
V-Tip: Long Life Tungsten Carbide (for vulcanized belts only)
- Available for Belt Widths 18" to 72" (450 to 1800mm). Other sizes available upon request.

Section 8 - Specs and CAD Drawings

8.2 CAD Drawing - FMS with MST Tensioners

FMS C CLEANER		SPECIFICATIONS				
ORDER NUMBER	ITEM CODE	BELT WIDTH 'A'		POLE LENGTH 'B'		# OF TIPS
		(in)	(mm)	(in)	(mm)	
FMSV-18	79637	18	450	72	1828	3
FMSV-24	79638	24	600	78	2133	4
FMSV-30	79639	30	700	84	2286	5
FMSV-36	79640	36	900	90	2438	6
FMSV-42	79641	42	1050	96	2590	7
FMSV-48	79642	48	1200	102	2743	8
FMSV-54	79643	54	1350	108	2895	9
FMSV-60	79644	60	1500	114	3200	10
FMSV-72	79645	72	1800	126	3750	12

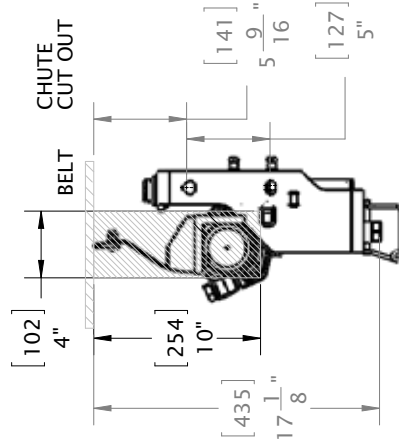
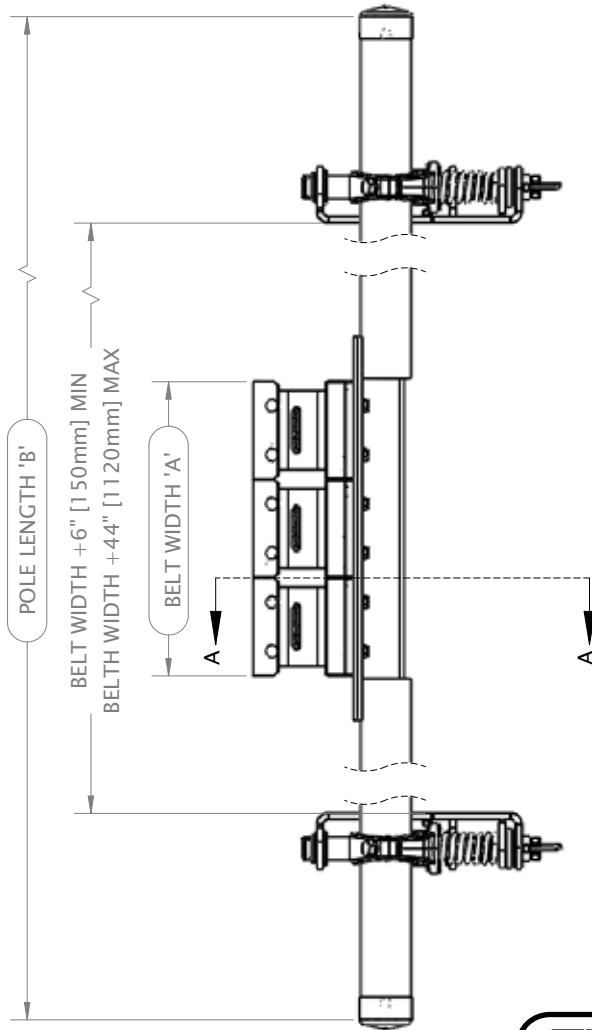
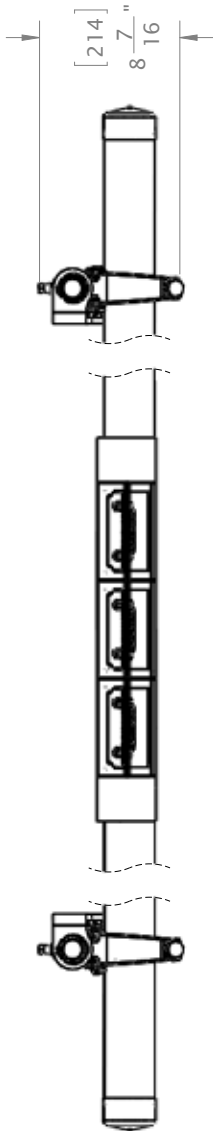

SECTION A-A

Section 9 - Replacement Parts

9.1 Replacement Parts List - FMS Secondary Cleaner

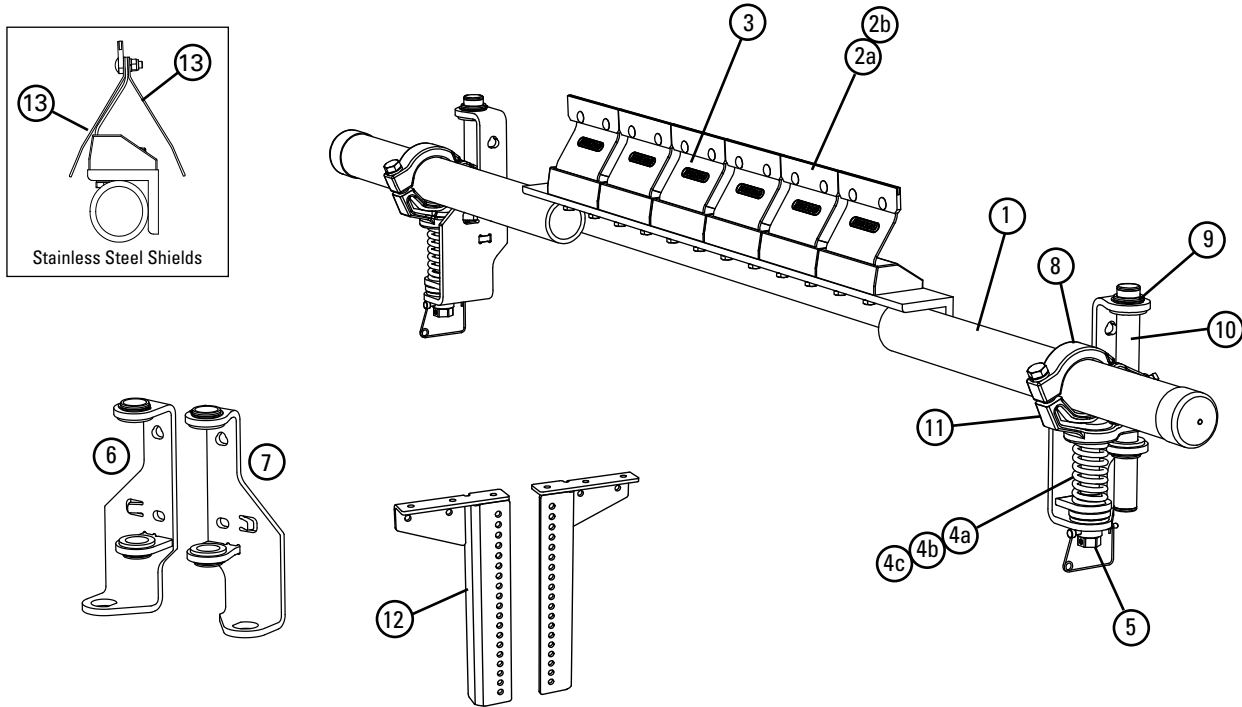

Replacement Parts

REF	DESCRIPTION	ORDERING NUMBER	ITEM CODE	WT. LBS.
1	18" (450mm) Pole	MHSP-18	76178	46.2
	24" (600mm) Pole	MHSP-24	75918	51.7
	30" (750mm) Pole	MHSP-30	75919	57.2
	36" (900mm) Pole	MHSP-36	75920	62.8
	42" (1050mm) Pole	MHSP-42	75921	68.3
	48" (1200mm) Pole	MHSP-48	75922	73.9
	54" (1350mm) Pole	MHSP-54	75923	79.4
	60" (1500mm) Pole	MHSP-60	75924	85.0
	72" (1800mm) Pole	MHSP-72	75925	96.1
2a	C-Tip*	ICT6	74535	0.7
2b	V-Tip* (for vulcanized belts only)	RSA150	73628	1.3
3	FMS Cushion Kit*	FMSC	79699	4.2
4a	Tension Spring - White (1 ea.) for belts 18" - 30" (450-750mm)	STS-W	75846	0.5
4b	Tension Spring - Silver (1 ea.) for belts 36" - 54" (900-1350mm)	STS-S	75843	0.8
4c	Tension Spring - Black (1 ea.) for belts 60" - 72" (1500-1800mm)	STS-B	75844	1.0
5	MST Adjusting Mechanism	MSTAM	79435	2.8
6	MST Mounting Bracket LH (incl. bushings)	MST-MBL	79436	5.7
7	MST Mounting Bracket RH (incl. bushings)	MST-MBR	79437	5.7
8	MST HD Clamp*	MSTCHD	79439	2.5
9	MST Bushing Kit (incl. 4 bushings)	MSTBK	79440	.2
10	MST Guide Pole	MSTGT	79441	1.5
11	MST HD Pole Mount*	MSTPMHD	79451	7.3
12	MST Drop Brackets (2)	MSTDB	79434	27.7
13	P SS Shield	PSSS	74773	.5
-	MST HD Tensioner w/White Spring* (incl. 1 ea. items 6, 7; 2 ea. items 4a, 5, 8, 10 & 11)	MSTHD-W	79431	36.8
-	MST HD Tensioner w/Silver Spring* (incl. 1 ea. items 6, 7; 2 ea. items 4b, 5, 8, 10 & 11)	MSTHD-S	79432	37.5
-	MST HD Tensioner w/Black Spring* (incl. 1 ea. items 6, 7; 2 ea. items 4c, 5, 8, 10 & 11)	MSTHD-B	79433	38.1

*Hardware Included
Lead time: 1 working day

MST Spring Tensioner Selection Chart

CLEANER SIZE	79431 MSTHD-W	79432 MSTHD-S	79433 MSTHD-B
FMS 18" - 30" (450 - 750mm)	X		
FMS 36" - 54" (900 - 1350mm)		X	
FMS 60" - 72" (1500 - 1800mm)			X

Section 10 - Other Flexco Conveyor Products

Flexco provides many conveyor products that help your conveyors to run more efficiently and safely. These components solve typical conveyor problems and improve productivity. Here is a quick overview on just a few of them:

MMP Precleaner



- Extra cleaning power right on the head pulley
- A 10" (250mm) TuffShear™ blade provides increased blade tension on the belt to peel off abrasive materials
- The unique Visual Tension Check™ ensures optimal blade tensioning and quick, accurate retensioning
- Easy to install and simple to service

DRX Impact Beds



- Exclusive Velocity Reduction Technology™ to better protect the belt
- Slide-Out Service™ gives direct access to all impact bars for change-out
- Impact bar supports for longer bar life
- 4 models to custom fit to the application

MDWS DryWipe Secondary Cleaner



- Wipes the belt dry as final cleaner in system
- Automatic blade tensioning to the belt
- Easy, visual blade tension check
- Simple, one-pin blade replacement

PT Max™ Belt Trainer



- Patented "pivot & tilt" design for superior training action
- Dual sensor rollers on each side to minimize belt damage
- Pivot point guaranteed not to freeze up
- Available for topside and return side belts

Flexco Specialty Belt Cleaners



- "Limited space" cleaners for tight conveyor applications
- High Temp cleaners for severe, high heat applications
- A rubber fingered cleaner for chevron and raised rib belts
- Multiple cleaner styles in stainless steel for corrosive applications

Belt Plows



- A belt cleaner for the tail pulley
- Exclusive blade design quickly spirals debris off the belt
- Economical and easy to service
- Available in vee or diagonal models

The Flexco Vision

To become the leader in maximising
belt conveyor productivity for our customers worldwide
through superior service and innovation.



2525 Wisconsin Avenue • Downers Grove, IL 60515-4200 • USA
Tel: (630) 971-0150 • Fax: (630) 971-1180 • E-mail: info@flexco.com

Visit www.flexco.com for other Flexco locations and products.

©2015 Flexible Steel Lacing Company. 6/15. For reorder: X3720

